

SPARTAN
OWNER'S
MANUAL

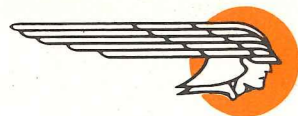

SERVICE AT YOUR COMMAND

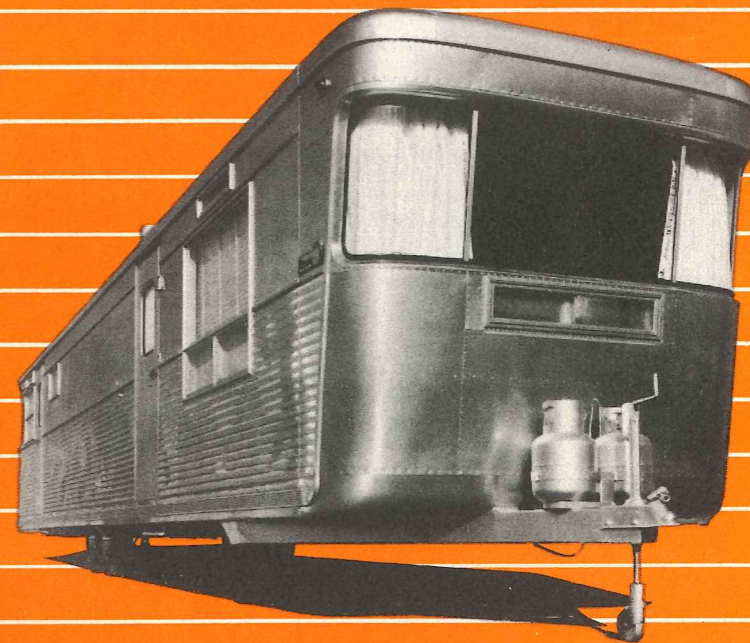

SPARTAN OWNER'S MANUAL

WELCOME
TO YOUR
NEW

**SPARTAN
HOME**

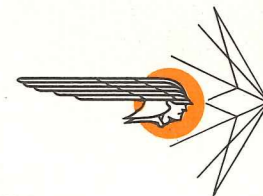

● WE AT SPARTAN are proud to welcome you — the new owner of a Spartan Mobile Home. There are millions of people who find mobile home living their preferred way of life and we want you to enjoy your Spartan to the fullest. As you move into your new Spartan home you will find many devices throughout to simplify your household chores and give you more time for diversion and recreation. Your Spartan Home is designed to give you the greatest possible livability, and as you become more acquainted with your new home and the new modern way of life, you will become aware

TO HELP YOU GET THE MOST FROM YOUR...

of the strict attention to details in the preparation of your new home. If it is possible to build a better home on wheels, Spartan will do it. We at Spartan want you to be happy with your new home, and if you have any questions regarding its care and maintenance not covered in this booklet, please contact your nearest Spartan authorized dealer. You will find the cities which have authorized Spartan dealers listed on Page 14. Look for his identification sign with the world-famous Spartan trademark. This is your sign of quality and trusted leadership. You will find your Spartan dealer friendly and helpful at all times. We believe you will find this booklet informative and helpful, and we suggest you read it carefully before settling down in your new home.



SPARTAN HOME

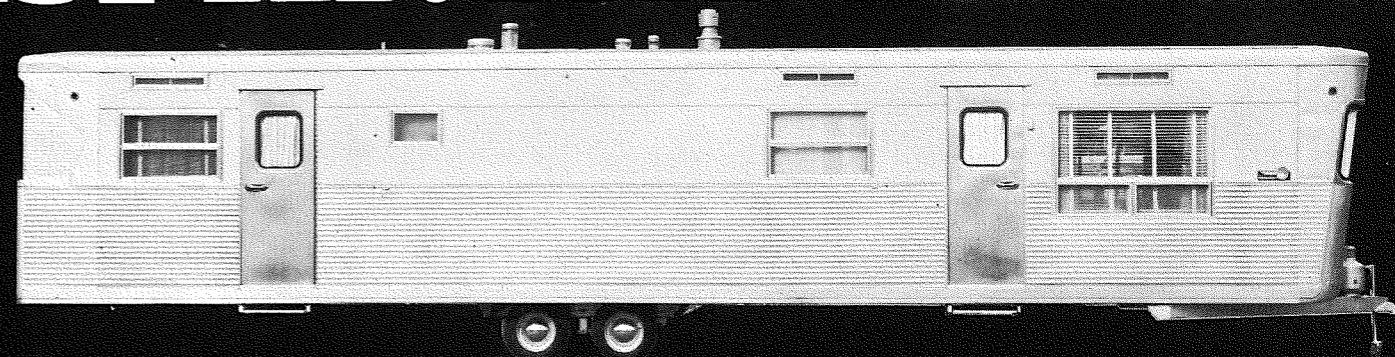

YOU CAN TAKE IT WITH YOU

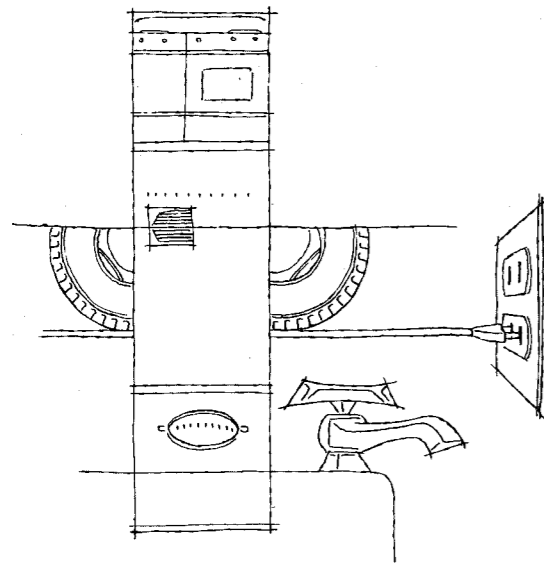

INFORMATION

Information and warranties on the following are furnished you by the manufacturer, and we suggest you keep this material handy for quick reference:

STOVE, HEATING
 STOVE, COOKING
 REFRIGERATOR
 WATER HEATER
 ELECTRICAL SYSTEMS
 BRAKES
 WASHING & DRYING MACHINES
 GARBAGE DISPOSAL

Important: Fill out the enclosed warranty card and return to Spartan immediately. Upon receipt of your card Spartan will mail your service coupons direct to you.

OPERATIONS

TO BACK AND TOW

YOUR DEALER will be glad to instruct you in the proper backing and towing of a mobile home.

DO NOT OVERLOAD YOUR MOBILE HOME

WHEN LOADING your Spartan Home for travel, keep the weight evenly distributed, front and rear.

CHOOSE GOOD PARKING GROUND

STUDY THE PARKING area before pulling or backing your mobile home onto it. Remember, your mobile home is likely heavier than your car. Do not take a chance and get stuck in soft ground or sand. If there is any doubt, it is best to get out and walk over the area, making a close inspection.

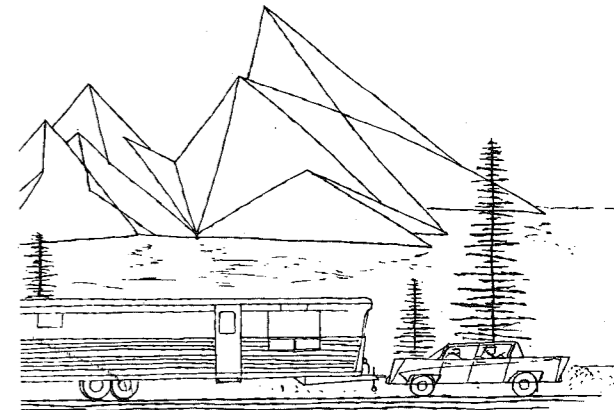

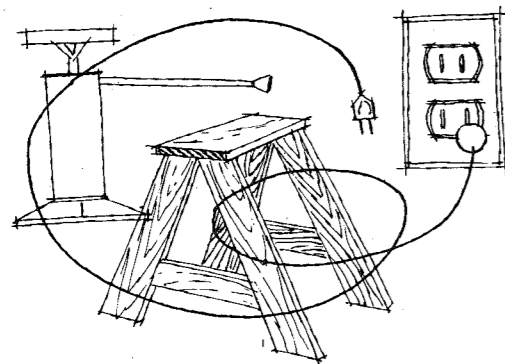
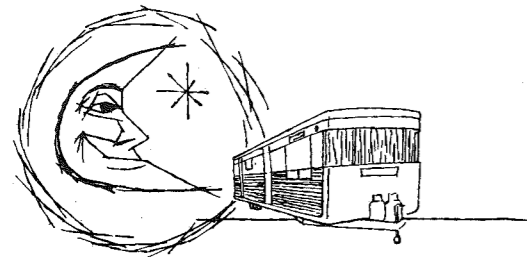

HOW TO STABILIZE AND BLOCK A MOBILE HOME

FOR OVERNIGHT PARKING

FOR OVERNIGHT PARKING, it is desirable to stabilize the mobile home enough to give it rigidity. Follow steps 1 and 2 outlined on page five. These two simple steps require no other jack than that in the mobile home coupler hitch.

FOR PROLONGED PARKING

ONCE YOUR MOBILE HOME is maneuvered into position at any location where it is to remain for any length of time, some stabilizing support is desirable. A very rigid type of stabilizing is important. For stabilizing jack see your dealer. Follow the 5-step blocking procedure as illustrated. It is required that you frequently recheck the supports as ground settles and rises with weather changes.

Have permanent 3 wire adapter for 3 wire service cord connected at 110 volt service box in trailer park.

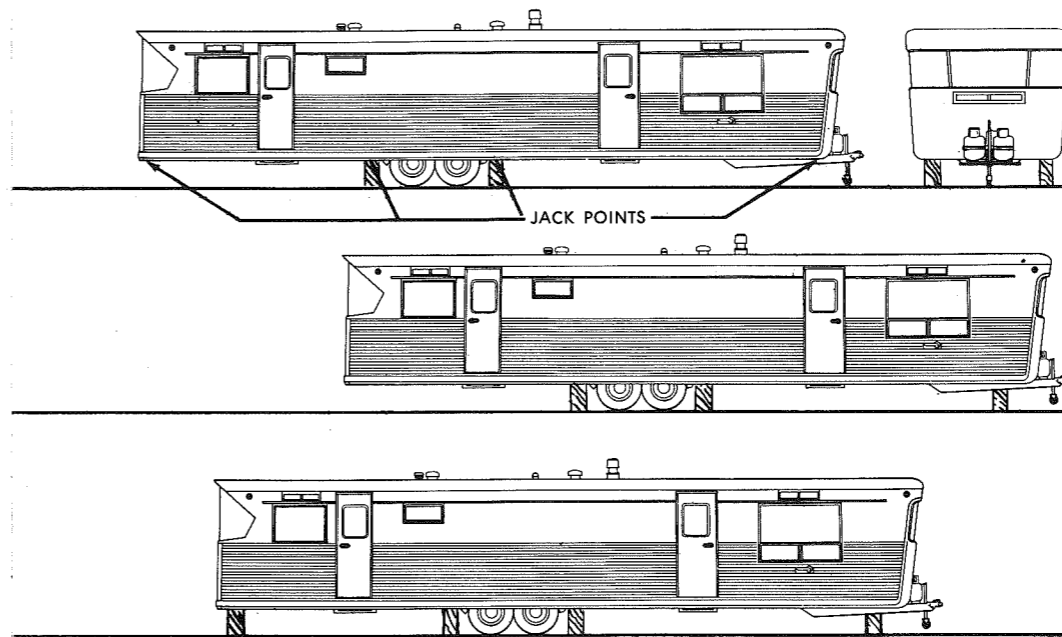

- 1 - Level coach lengthwise with hitch jack.
- 2 - Level coach crosswise - place jack under axle and level coach crosswise with permanent blocks or jacks at frame jack points, forward and aft of axles on both sides of coach.

- 3 - Re-check level both lengthwise and crosswise.
- 4 - Raise coach with hitch jack just high enough to place blocks under front jack points. Then lower coach until pressure is applied on blocks and coach is in level position.

- 5 - Place jack just forward of rear points and raise coach just high enough to place blocks under rear jack points. Lower coach until pressure is applied to blocking and coach is level.

NOTE - Forward and aft blocks are to stabilize coach - main load to be carried by four center blocks.

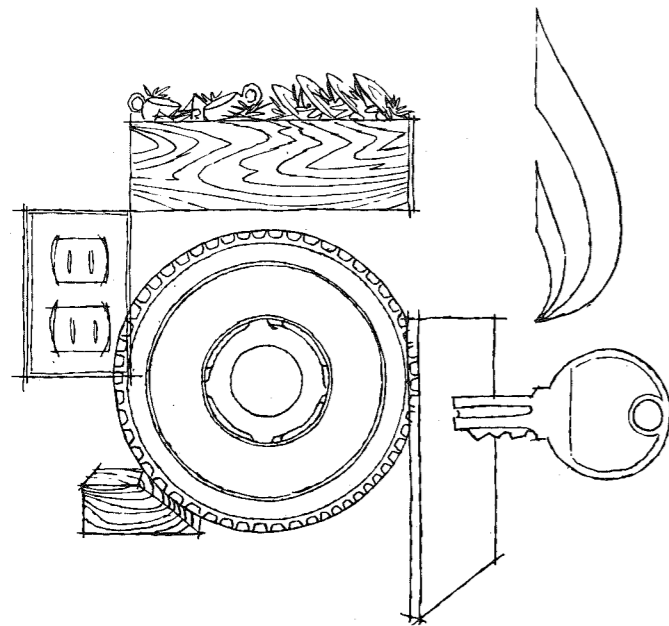

GETTING READY FOR THE ROAD

PAD ALL BREAKABLE ITEMS. Put packing around stacks of dishes — towels will do. Turn off the cooking gas at the tank outside. Couple the electric connection between car and coach; test the mobile home running lights. Hook up safety chains. Disconnect all water, sewer and electrical lines. Drain flush tank. Close all windows and roof ventilators. Lock outside doors *securely*. Slide the outside metal steps securely under the mobile home. Do not travel with heating stove in operation. See that hitch ball is properly engaged and locked. Remove wheel blocks the last thing before you start to roll. By the same token, wheel blocks should be set under mobile home wheels first thing when you've arrived at your destination — even before uncoupling. Remember, most mobile home brakes can't be applied when the car is uncoupled, and at no time should anyone ride in a moving mobile home.

HOW TO DRIVE WHEN TOWING A MOBILE HOME

APPLYING THE BRAKES

YOUR SPARTAN is equipped with *electric* brakes on all wheels. Some types of mobile home brakes are manually controlled by a lever installed on the car's steering column close to the steering wheel; other types are actuated by the same foot pedal as are the car brakes. Controllers on the latter types can be adjusted to apply the coach brakes an instant before the car brakes, when the foot pedal is actuated.

If the brakes on your coach are controlled independently of the car brakes, it's a good rule to apply your coach brakes first when stopping, especially when making a sudden stop on wet pavements. Use a quick off-and-on motion in applying mobile home brakes, rather than a steady application. If coach starts to sway, apply your coach brakes lightly but not your car brakes. *Remember*, if you apply car brakes first, your mobile home will sway or have a tendency to jack-knife.

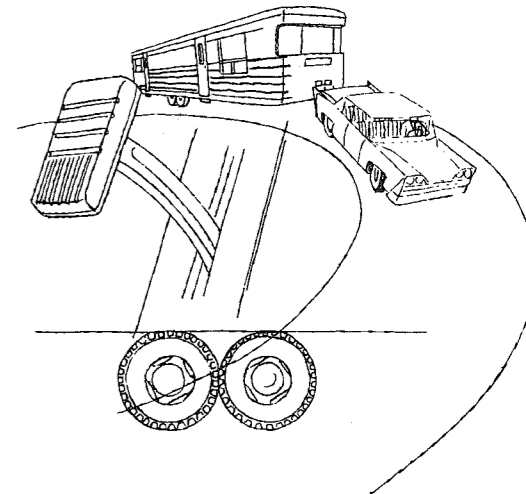

CARE OF UNDERCARRIAGE

ADHERENCE to a few simple rules can avoid some possible costly experience later on with the undercarriage. This is the term applied to the assembly consisting of tires, wheels, brakes, axles and springs.

Care and maintenance of undercarriage is important and should be given same attention as the chassis of your automobile.

ATTENTION TO TIRES

GOOD TIRES are a necessity. Frequent checks should be made to guarantee correct, uniform pressure in all tires.

CHECK WHEEL HUB BOLTS

WHEEL HUB BOLTS sometimes work loose, so it is a good idea to inspect and tighten all hub bolts on trailer wheels before starting on a trip, and every few hundred miles thereafter.

WHEELS AND BRAKES

THE BRAKES on your Spartan normally require very little attention. However, regular inspection and testing should be made, just as with your automobile. If your Spartan has been parked for a prolonged period, have the brakes checked by an authorized brake mechanic before using. Electrical connections for brakes should always be kept clean and tight.

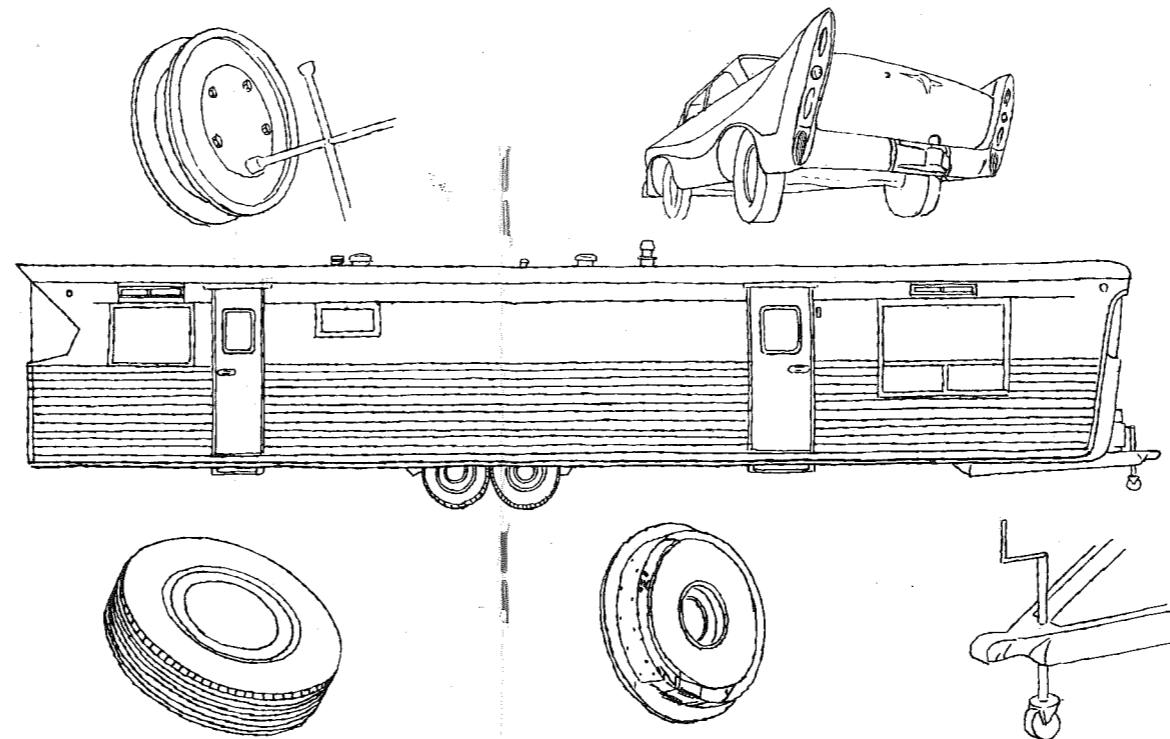

HITCH

HITCH SHOULD BE MAINTAINED in good condition at all times and hitch ball lubricated at all times when in transit and keep locking device well secured. Bolts securing hitch coupler to "A" frame should be tightened prior to moving.

CAR'S TOWING DEVICE

THE INSTALLING of a towing device ("car hitch") on the coach owner's car is usually worked out by the owner with the assistance of the dealer who sells the coach.

Your Spartan dealer will advise you concerning the use of dollies, overload springs, and weight distributing hitches. To install some types of weight distributing hitches, when weight loads are abnormally heavy it is advisable to reinforce "A" frame where excessive loads are concentrated.

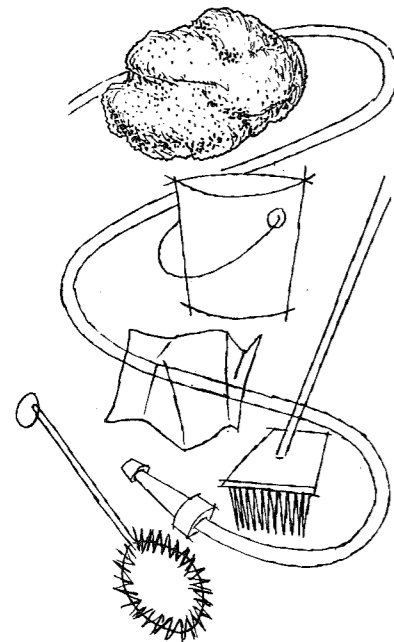

CARE OF EXTERIOR

GENERALLY SPEAKING, the exterior finish on your mobile home requires about the same care and upkeep as the finish on your car. With reasonable attention the outside of your coach can be preserved so that it will render long and satisfactory service.

When a mobile home is cleaned regularly, the finish is protected. Protective measures are particularly important in seaboard localities exposed to salt air and in industrial areas where smoke fumes and gasses prove highly corrosive. Always chamois down after washing.

CLEANERS

These are available in both paste and liquid form, and are formulated to loosen accumulation of road film, scum, oil, tree sap, and grime which cannot be removed by washing.

Check with local chemical companies or airports on cleaners recommended for cleaning all-aluminum surfaces.

PLEXIGLAS

To clean Plexiglas wash with plenty of soap and water using the bare hand to feel and dislodge any caked dirt or mud. A soft cloth, sponge or chamois may be used. Dry with a clean damp chamois. Do not use gasoline, alcohol, benzene, acetone, carbon tetrachloride, fire extinguisher or de-icing fluid, lacquer thinners or glass window cleaning sprays, as they will soften the plastic and may cause crazing.

CONDENSATION AND VENTILATION

The problem of condensation in all types of dwellings, including mobile homes, always exists during cold winter weather. Warm air has the ability to hold much more moisture than cold air, and the tendency is for water vapor to move from a warmer to a cooler place, thereby causing condensation. Mobile homes must be kept comfortably warm, and since moisture is added to the air by cooking, washing, etc., trying to keep the relative humidity of the air to the low degree needed to prevent condensation is not always possible.

DISCOLORED PLYWOOD PANELS

If the interior plywood should become soiled, it can be cleaned with suds from a mild soap — like a flax or oil soap. Or, wash or wipe with a sponge dipped in a solution of two tablespoons of household ammonia to three quarts of lukewarm water, and then wipe dry.

Discoloration and checking of interior finish and of the plywood to which it is applied are particularly

noticeable in frigid climates where a maximum of heat is required during the winter. After a coach has been left without heat in winter, make sure temperature is raised very slowly. Some expansion and contraction of plywood and of solid lumber is a normal occurrence, due to changes in humidity. If this should cause cabinet doors to stick, this may be remedied by using a block plane.

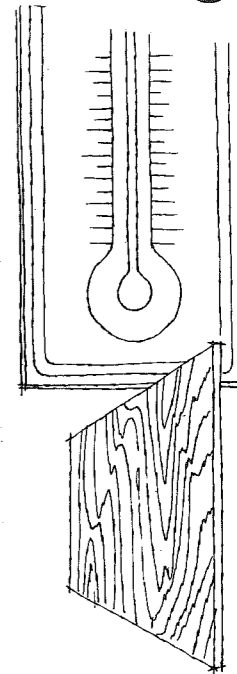

WHAT CAUSES CONDENSATION

The modern conveniences of mobile home living today have added to the problem of condensation, notably the gas cook stove, and the shower bath which all add to moisture in the air. Open gas flames produce hydrogen as one of the products of combustion, and this combining with the oxygen of the air produces water. In fact, the burning of one gallon of LP gas, in this manner, actually produces approximately one gallon of water in the coach. This is why your Spartan is equipped with a canopy and a vent directly over the gas range. This vent should remain open at all times and is equipped with a fan. This fan should be turned on to carry excess moisture to the outside and thereby help prevent excessive "sweating" in the trailer.

WHEN TAKING A SHOWER

When taking a shower, the door to the shower room should be closed during bathing and should remain closed for thirty or forty minutes afterwards to allow the moisture created to escape out the vent to the outside air. The vent in the shower room should likewise remain opened and is equipped with a fan. Laundering and hanging of wet clothes in trailers also adds to the moisture in the air.

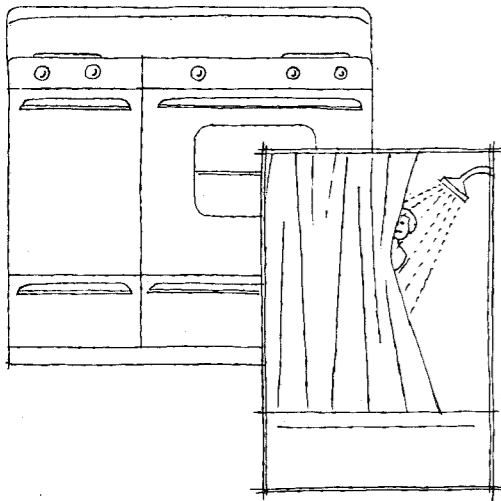

PROPER VENTILATION

Condensation can be prevented to a great extent by heat and ventilation. In the summer time, because doors and windows are usually open, water or vapor generated in the mobile home readily escapes. It is quite obvious that closing the mobile home tight, permitting no moisture to escape continually adds moisture to the air. It is absolutely necessary to have one roof ventilator partially opened together with one window. This can be arranged so it is not creating a draft, and at the same time permits cool outside air with low humidity to enter and lower the moisture content. This will also add greatly to heating comfort for hot air laden with moisture produces a sticky uncomfortable condition.

If your Spartan Home is equipped with power vents, care should be taken in the operation of the vent fans to prevent a back draft on the space heater. In other words, you must let as much fresh air into your Spartan home as you expect to exhaust through the power vents.

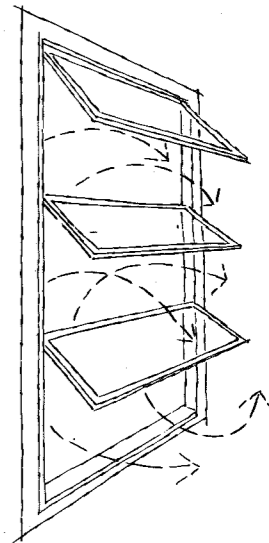

LOCATION OF
SPARTAN
SALES AND
SERVICE

ALABAMA
Birmingham
Huntsville
Mobile
Montgomery

ALASKA
Kodiak

ARIZONA
Flagstaff
Phoenix
Tucson
Yuma

ARKANSAS
Blytheville
Fort Smith
Hot Springs
Little Rock
West Memphis

CALIFORNIA
Bakersfield
Crescent City
El Monte
Fresno
Lancaster
Long Beach
Los Angeles
Modesto
Mountain View
Newport Beach
North Sacramento
Palm Springs
Redding
Riverside
Salinas
San Diego
San Leandro
Santa Clara
Stockton
Van Nuys

COLORADO
Colorado Springs
Cortez
Denver
Grand Junction
Lamar

CONNECTICUT
East Hartford
Waterbury
Westbrook

DELAWARE
Seaford
Wilmington

FLORIDA
Bradenton
Daytona Beach
Eau Gallie
Ft. Lauderdale
Ft. Walton Beach
Jacksonville
Lakeland
Lake Worth
Melbourne
Miami
Ocala
Orlando
Pensacola
St. Petersburg
Sarasota
Tallahassee
Tampa
Tice

GEORGIA
Albany
Atlanta
Augusta
Brunswick
Columbus

Macon
Savannah
Warner Robins

IDAHO
Boise
Idaho Falls

ILLINOIS
Aurora
Chicago
Decatur
East St. Louis
Peoria
Rantoul
Raymond
Rockford
Springfield
Van Orin
Waukegan

INDIANA
Anzola
Bunker Hill
Evansville
Ft. Wayne
Hobart
Indianapolis
Mishawaka
Michigan City
Peru
Salem
Terre Haute

IOWA
Ames
Keokuk
Marion
Sioux Center

KANSAS
Liberal

Manhattan
Oakley
Wichita

KENTUCKY
Ashland
Louisville

LOUISIANA
Alexandria
Baton Rouge
Bossier City
Houma
Lake Charles
New Orleans
Westwego

MAINE
Bangor
Brunswick
Portland

MARYLAND
Baltimore
Hagerstown
Pocomoke City
White Plains

MASSACHUSETTS
Belchertown
Cheshire
West Peabody

MICHIGAN
Flint
Grand Rapids
Monroe
Van Dyke
Warren (Detroit)

MINNESOTA
Duluth

East Grand Forks
Minneapolis
Moorhead
Virginia

MISSISSIPPI
Biloxi
Greenville
Jackson
Natchez

MISSOURI
Columbia
Joplin
Kansas City
Robertson
Rolla
Springfield

MONTANA
Billings
Butte
Glendive
Missoula

NEBRASKA
Lincoln
Neligh
North Platte
Omaha
Sidney

NEVADA
Las Vegas
Reno

NEW HAMPSHIRE
Keene

NEW JERSEY
Atlantic City
Bound Brook
Bordentown

Thorofare
Woodbury

NEW MEXICO
Alamogordo
Albuquerque
Clovis
Farmington
Hobbs
Raton
Roswell
Silver City

NEW YORK
Eagle Mills
East Syracuse
Hamburg
Ogdensburg
Plattsburg
Port Ewen
Whitney Point
Yonkers

NORTH CAROLINA
Asheville
Charlotte
Fayetteville
Greensboro
Jacksonville
Rocky Mount

NORTH DAKOTA
Bismarck
Dickinson
Leeds
Minot
Ray

OHIO
Akron
Cincinnati
Cleveland
Dayton

Greenville
Kent
Lima
Madison
Piketon
Reading
Reynoldsburg
Steubenville

OKLAHOMA
Altus
Ardmore
Enid
Oklahoma City
Tulsa

OREGON
Baker
Coos Bay
Eugene
Klamath Falls
Madras
Medford
Portland
The Dalles
Umatilla
Roseburg

PENNSYLVANIA
Allentown
Carmichaels
Lancaster
Odessa
San Angelo
San Antonio
Sherman
Middletown
Monaca
Phoenixville
Pittsburgh
State College

RHODE ISLAND
East Greenwich

SOUTH CAROLINA
Barnwell
Charleston Heights
Greenville
West Columbia

SOUTH DAKOTA
Rapid City
Sioux Falls
Watertown

TENNESSEE
Chattanooga
Knoxville
Nashville

TEXAS
Abilene
Amarillo
Austin
Beaumont
Big Spring
Corpus Christi
Dallas
El Paso
Ft. Worth
Harlingen
Houston
Longview
Lubbock
Odessa
San Angelo
San Antonio
Sherman
Victoria
Waco
Weslaco
Wichita Falls

UTAH
Salt Lake City

VIRGINIA
Blacksburg
Norfolk
Richmond

WASHINGTON
Burlington
Pasco
Seattle
Spokane
Tacoma
Moses Lake

WEST VIRGINIA
Bluefield
Clarksburg

WISCONSIN
Caledonia
Fond du Lac
Germantown
Madison
Menomonie

WYOMING
Casper

ALASKA
Anchorage
Fairbanks

CANADA
Calgary, Alberta
Regina, Saskatchewan
South Burnaby, B. C.

ARABIA
Kuwait, Arabian Gulf

SWITZERLAND
Geneva

INDEX

Backing and Towing	3
Blocking	4, 5
Condensation	11, 12, 13
Exterior, Care of	10
Getting Ready for the Road	6
Overloading	3
Parking	3, 4
Stabilizing	4
Towing	7
Undercarriage, Care of	8
Ventilation	11, 12, 13
Warranty	16
Service Data, Accessories and Appliances	2

WARRANTY

The manufacturer warrants each new Spartan Aircraft Trailercoach, manufactured by it, to be free from defects in material and workmanship, under normal use and service, its obligation under this warranty being limited to making good at its factory any part or parts thereof, which shall within ninety (90) days after making delivery of such trailercoach to the original retail purchaser be returned to the factory in Tulsa, Oklahoma, with transportation charges prepaid and which its examination shall disclose to its satisfaction to be thus defective; this warranty being expressly in lieu of all other warranties, expressed or implied, and of all other obligations or liability on its part of any kind or character, including liabilities for alleged representations or negligence, and the manufacturer does not assume any liability other than that herein assumed, nor authorizes any other person to assume for it any liability in connection with the sale of its trailercoaches. This warranty shall not apply to any trailercoach which shall have been repaired or altered outside the factory of the manufacturer in any way so as, in the judgment of the manufacturer, to affect its stability or reliability, or which has been subject to misuse, negligence or accident. The manufacturer makes no warranty whatsoever in respect to tires, rims, brakes, axles and wheels, springs, beds, divans, paint, stoves, refrigerators, linoleum, or any parts and accessories not manufactured by it, but the manufacturer agrees to extend and pass on, so far as possible, to the benefit of the original purchaser, all guarantees or warranties of the manufacturers of such articles without in any way assuming responsibility or liability therefor. The right is reserved to make changes in specifications or design without notice.